

Part number

CHP 50.229



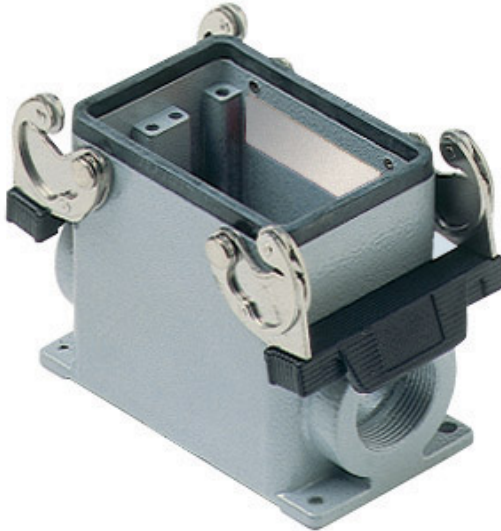

Brief description:

surface mounting housings with 2 levers, size "66.40", Pg29 x 2, metal version, IP66



Product description	
Version	metal version
Series	surface mounting housings with 2 levers
Product type	with 2 levers
Family	CLASS enclosures
Size	size "66.40"
Technical data	
Material	metal
IP degree of protection	IP66 (and IP69K DIN 40050 - 9)
Cable entry	Pg29 x 2
Further technical details	
Weight	440,00 g

Approvals / Standards	
Quality mark	 (type:4/4X/12),  , EAC
Conformity	CQC, CE
General ordering information	
EAN13 code	8015747023283
Tariff number	85369095
Packaging Information	
Packaging length	145,00 mm
Packaging height	105,00 mm
Packaging width	350,00 mm
Packaging weight	2,40 kg
Packaging volume	5,33 dm ³
Packaging description	Carton box
Packaging quantity	5 Pcs
Packaging EAN code	8015747023290

Part number

CHP 50.229



Catalogue drawings

CHP - MHP

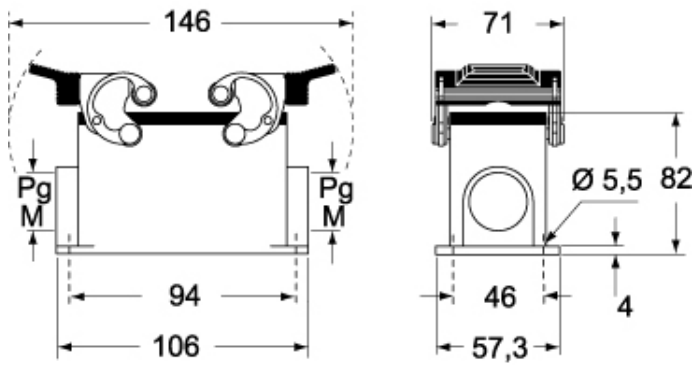

CHP CS - MHP CS

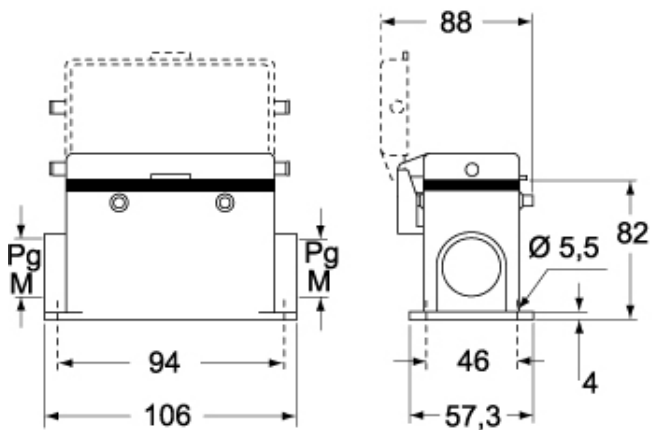

Catalogue drawings

